

Twin Wall Spot

Cat. No. TWS

Cat. No. TWS/R

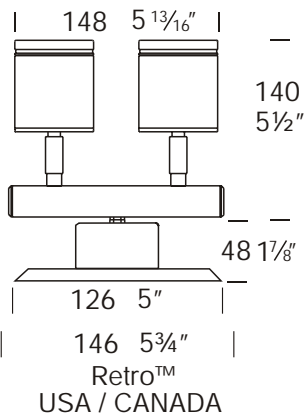
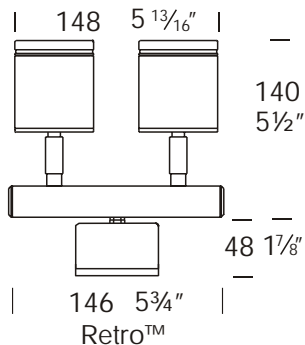
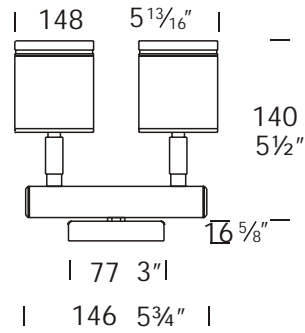

The two individual spotlights can be aimed in entirely different directions allowing 360 degree rotation and 0 - 90° elevation and are water-resistant.

The Retro™ is a 110/240 ac mains option suited to an installation where mounting a transformer is a problem, e.g. a brick wall where there is only the cable protruding out of the wall and it is not an option to recess the transformer or when replacing an existing light fitting. The base size increases in size to accommodate the encapsulated IP66 dimmable transformer.

Ordering Information

Luminaire Type	Material/Finish	Accessories
TWS - Twin Wall Spot	BK - Black BZ - Bronze GN - Green MS - Metallic Silver WH - White COP - Copper SS - 316 Stainless Steel	CJK150 - Cable Joint Kit DFL - Frosted Lens GG - Glare Guard HCL - Hex Cell Louvre Adaptor /R - Retro™ Transformer 110/240 volt WBAP - Wall Box Adaptor Plate
Ordering Example	TWS GN - Twin Wall Spot in Green TWS/R BZ - Twin Wall Spot Retro™ in Bronze	DFL - Frosted Lens (Accessories ordered separately)



Patent Pending



FACTORY: Ph: 64-9-528 9471 Fax: 64-9-528 9361.
 USA: Ph. 310 560 7310 Fax. 1 877 692 4589.
 hunza@hunza.co.nz www.hunza.co.nz
 Specifications may change without notice.

130 Felton Matthew Ave, Glen Innes, Auckland, New Zealand.
 3237 Long Island St, W. Sacramento, California 95691, USA.
 Manufactured in New Zealand.

© 2003 Hunza Holdings Ltd

Luminaire Construction

CNC machined from one of the following metals:

Body: High corrosion resistant low copper 63.5mm (2½") x 10mm (25/64") aluminium. End cap - solid aluminium 63.5mm (2½") rod,.

Base & Mounting Plate (Retro™): Cast from virgin high corrosion resistant CC401 low copper aluminium alloy chromate substrate and high UV resistant polyester powder coat - Black, Bronze, Green, Metallic Silver, White.

Body: Copper 63.5mm (2½") x 10mm (25/64). End cap - solid copper 63.5mm (2½") rod.

Base: Copper Hand spun 2mm (5/64")

Mounting Plate: Forged brass (Retro™).

Body: Stainless steel 316 63.5mm (2½") x 10mm (25/64) rod. End cap - 316 stainless steel 63.5mm (2½") rod.

Base: Investment cast and CNC machined.

Mounting Plate: Investment cast and CNC machined. (Retro™)

Mounting

12 volt: the luminaire is mounted to the wall using two 316 stainless screws through a shallow base 16mm (5/8") in depth. A Wall Box Adaptor Plate (Cat. WBAP) is available as an accessory to fit 3.0 and 4.0 junction boxes for USA /Canada.

Retro™ luminaire (110/240 volt) : a mounting plate is fixed to the wall using two screws and then the luminaire is fitted to the mounting plate.

Features

Lenses:

3mm (1/8") thick clear tempered shatter resistant glass.
Life Time Warranty.

Gaskets:

Silicone, iron impregnated 220°C (428°F).

Lamp Holders:

GU5.3 - 350°C (662°F) ceramic multi contact lamp holder with 250°C (480°F) teflon cables.

Accessories:

CJK150 Cable Joint Kit (Cat.CJK150)
Not approved for USA /Canada.

Frosted Lens (Cat. DFL).

Glare Guard (Cat. GG.)

Hex Cell Louver Adaptor (Cat. HCL)

Retro™ transformer 110/240 volt (Cat. /R)

Wall Box Adaptor Plate (Cat. WBAP)
12 volt luminaire USA / Canada)

Swivel:

Aluminium and Copper luminaires - 360° rotation and 0 - 90° elevation, solid brass with anti rust spring.

Stainless Steel luminaires - 360° rotation and 0 - 90° elevation, full stainless steel construction.

Standards

IP66 AS/NZS61046  UL1838

Luminaire Weight

12 volt

Alum .775kg (1lb 11oz)

Cop 2.230kg (4lb 14oz)

SS 1.750kg (3lb 13oz)

Retro™

Alum 1.100kg (21lb 6oz)

Cop 2.650kg (5lb 13oz)

SS 2.200kg (4lb 13oz)

Power Supply

12 volt

HUNZA® Inground or HUNZA® Wall Mount Transformer: not included.

USA/ Canada

HUNZA® Wall Mount Transformer: not included

RETRO™

HUNZA® 110/240 volt ac silicone encapsulated electronic transformer built into the Retro™ base. Dimmable with a suitable leading edge dimmer.

Luminaire: supplied with

MR16 GU5.3 2 x 20, 35 or 50 watt lamps max.

Retro™

MR16 GU5.3 2 x 20 watt lamps max.
USA and Canada

MR16 GU5.3 2 x 20 or 35 watt lamp max.

Retro™

MR16 GU5.3 2 x 20watt lamps max.

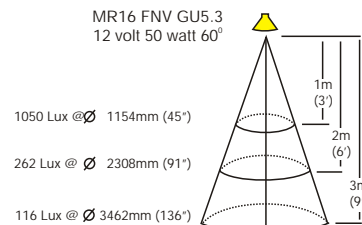
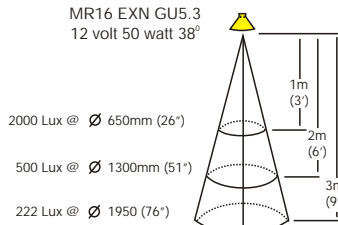
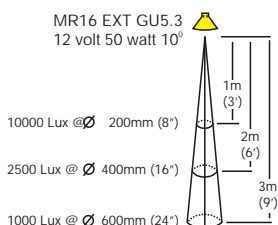
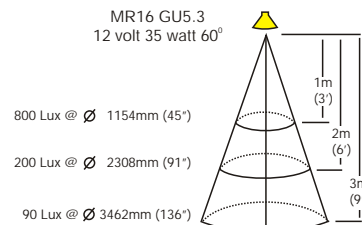
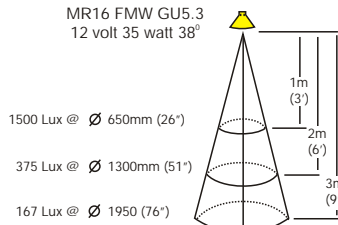
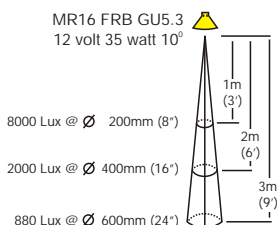
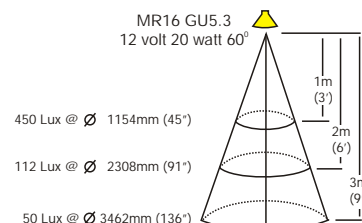
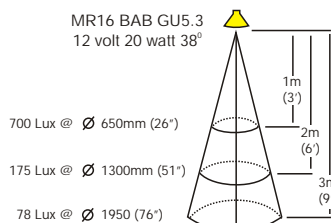
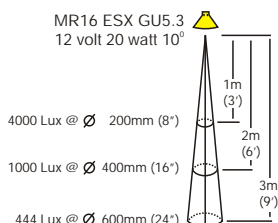

FACTORY: Ph: 64-9-528 9471 Fax: 64-9-528 9361.

USA: Ph. 310 560 7310 Fax. 1 877 692 4589.

hunza@hunza.co.nz www.hunza.co.nz

Specifications may change without notice.

130 Felton Matthew Ave, Glen Innes, Auckland, New Zealand.

3237 Long Island St, W. Sacramento, California 95691, USA.

Manufactured in New Zealand.

© 2003 Hunza Holdings Ltd