

Twin Bar Lite

Cat. No. TBL



Two individual spot lites which can be aimed in two entirely different directions. Each lite has fully adjustable arms allowing 360 degree rotation and 0 - 90 degree elevation adjustment.

The heads are mounted on a 250mm (10") bar with twin ground spikes.

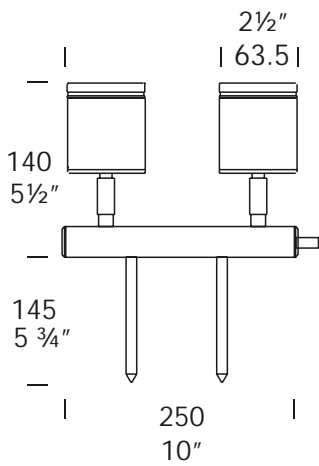

Ordering Information

Luminaire Type

TBL - Twin Bar Lite

Material/Finish

BK - Black
 BZ - Bronze
 GN - Green
 MS - Metallic Silver

COP - Copper
 SS - 316 Stainless Steel

Accessories

CJK150 - Cable Joint Kit
 DFL - Frosted Lens
 GG - Glare Guard
 HCL - Hex Cell Louvre Adaptor
 /300 - 300 (12") Spike

Ordering Example TBL COP - Twin Bar Lite in Copper
 TBL /300 BZ - Twin Bar Lite in Bronze
 with 300mm (12") Spike

HCL BK - Hex Cell Louvre Adaptor in Black
(Accessories ordered separately)



Patent Pending



FACTORY: Ph: 64-9-528 9471 Fax: 64-9-528 9361.
 USA: Ph. 310 560 7310 Fax. 1 877 692 4589.
 hunza@hunza.co.nz www.hunza.co.nz
 Specifications may change without notice.

130 Felton Matthew Ave, Glen Innes, Auckland, New Zealand.
 3237 Long Island St, W. Sacramento, California 95691, USA.
 Manufactured in New Zealand.

© 2003 Hunza Holdings Ltd

Luminaire Construction

CNC machined from one of the following metals:

High corrosion resistant 63.5mm (2½") x 10mm (25/64") aluminium.
End cap - solid aluminium 63.5mm (2½") rod, with chromate substrate and high UV resistant polyester powder coat -

Colours Black, Bronze, Green, Metallic Silver.

Copper 63.5mm (2½") x 10mm (13/32"). End cap - solid copper 63.5mm (2½") rod.

Stainless steel 316 9mm (11/32"). End cap - solid 316 stainless steel 63.5mm (2½") rod.

Mounting

Spike 150mm (6") 300mm (12") mounted directly into the ground.

Features

Lens:
3mm (1/8") clear tempered shatter resistant glass. Life Time Warranty.

Gaskets:
Silicone, iron impregnated 220°C (428°F).

Lamp Holders:
GU5.3 - 350°C (662°F) ceramic multi contact lamp holder with 250°C (480°F) teflon cables.

Accessories:
Cable Joint Kit (Cat.CJK150).
Not approved for USA /Canada.

Frosted Lens (Cat. DFL).

Glare Guard (Cat. GG).

Hex Cell Louvre Adaptor (Cat. HCL).

Ground Spike 300mm (12") (Cat. /300).

Swivels :

Aluminium and Copper luminaires - 360° rotation and 0 - 90° elevation, solid brass with anti rust spring.

Stainless Steel luminaires - 360° rotation and 0 - 90° elevation, full stainless steel construction.

Standards

IP66



UL1838

Luminaire Weight

Alum 1.060 kg (2lb 5oz)

Cop 2.840 kg (6lb 4oz)

SS 2.420kg (5lb 5oz)

Power Supply

HUNZA® Inground or Wall Mount Transformer: not included.

USA and Canada:

HUNZA® Wall Mount Transformer: not included.

Luminaire: supplied with

MR16 GU5.3 - 2 x 20, 35 or 50 watt lamps max.

USA and Canada:

MR16 GU5.3 - 2 x 20 watt lamps.

When glare guard fitted lamp wattage can be increased to 35 watt.

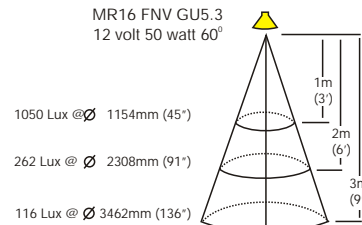
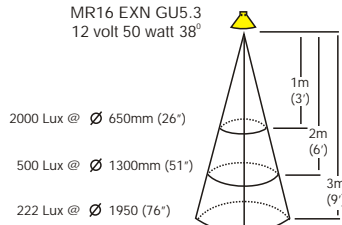
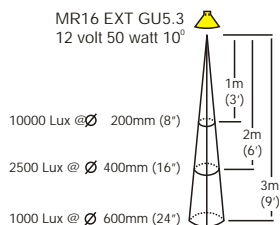
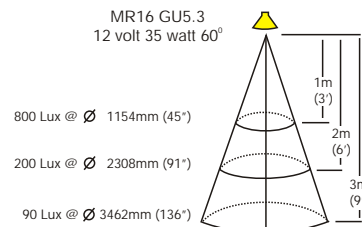
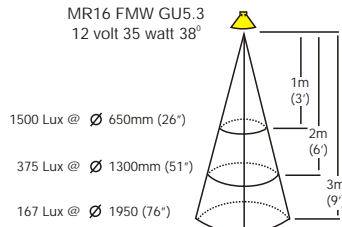
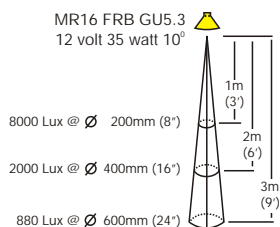
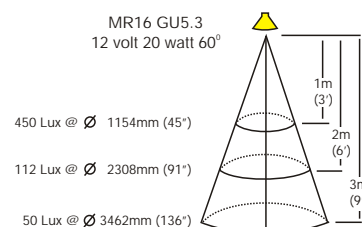
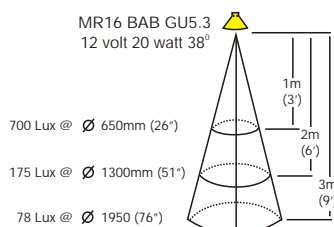
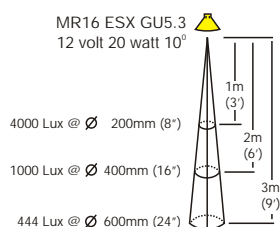

FACTORY: Ph: 64-9-528 9471 Fax: 64-9-528 9361.
USA: Ph. 310 560 7310 Fax. 1 877 692 4589.
hunza@hunza.co.nz www.hunza.co.nz
Specifications may change without notice.

130 Felton Matthew Ave, Glen Innes, Auckland, New Zealand.
3237 Long Island St, W. Sacramento, California 95691, USA.
Manufactured in New Zealand.

© 2003 Hunza Holdings Ltd