

# Pool Lite

Cat. No. PLSS

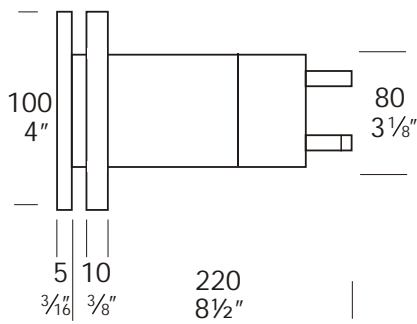

Pool Canister  
(Supplied with Luminaire)

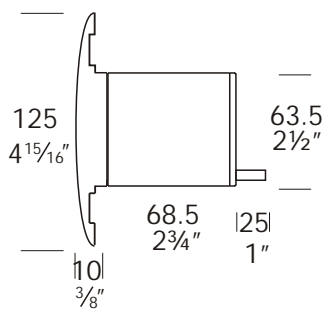

Pool Lite is electro polished for extra corrosion protection and is held into the PVC canister by two 'O' rings. There are no mounting screws in the flange to spoil the aesthetics of this luminaire. Up to 600mm (2') of cable can be coiled up inside the mounting canister enabling the luminaire to be removed for lamp changing above the water line. Complete with six metres (18') of submersible cable. Longer cable available on request.

## Ordering Information

Luminaire Type

Material

Accessories

PLSS - Pool Lite

316 Stainless Steel

CJK150 - Cable Joint Kit

HCL - Hex Cell Louvre Adaptor

DFL - Frosted Lens

Ordering Example PL SS - Pool Lite in 316 Stainless Steel  
with PVC Canister

CJK150 - Cable Joint Kit

(Accessories ordered separately)

Patent Pending



FACTORY: Ph: 64-9-528 9471 Fax: 64-9-528 9361.

USA: Ph: 310 560 7310 Fax: 1 877 692 4589.

hunza@hunza.co.nz www.hunza.co.nz

Specifications may change without notice.

130 Felton Matthew Ave, Glen Innes, Auckland, New Zealand.

3237 Long Island St, W. Sacramento, California 95691, USA.

Manufactured in New Zealand.

© 2003 Hunza Holdings Ltd

## Luminaire Construction

CNC machined from:

Body: 316 stainless steel 9mm (11/32").

End cap: solid 316 stainless steel 63.5mm (2 1/2") rod. This luminaire is electro polished to improve corrosion resistance by up to 33%.

### Canister:

CNC machined from engineering grade PVC with moulded PVC end cap which has 20mm (3/4") conduit entry for electrical connections.

## Mounting

The PVC mounting canister is suitable for installation into three different types of pool wall:

- 1) Fibreglass pools,
- 2) Existing concrete pools,
- 3) New concrete pools.

## Features

### Lens:

3mm (1/8") thick clear tempered shatter resistant glass

Life Time Warranty.

### Gaskets:

Silicone, iron impregnated 220°C (428°F).

### Lamp Holder:

GU5.3 - 350°C (662°F) ceramic multi contact lamp holder with 250°C (480°F) teflon cables.

### Cable:

1.3mm (16AWG) x 6 metres (18') submersible cable, longer cable available on request.

### Accessories:

Cable Joint Kit (Cat. CJK 50) Not approved for USA /Canada.

Frosted Lens (Cat. DFL).

Hex Cell Louver Adaptor (Cat. HCL).

## Standards

IP68



UL676

## Luminaire Weight

1.885kg (4lbs 2oz)

## Power Supply

HUNZA® H50: not included.

### USA and Canada:

Ground Shield Transformer: not included.

## Luminaire: supplied with

MR16 GU5.3 20, 35, 50 watt lamp max.

### USA and Canada:

MR16 GU5.3 20, 35, 50 watt lamp max.

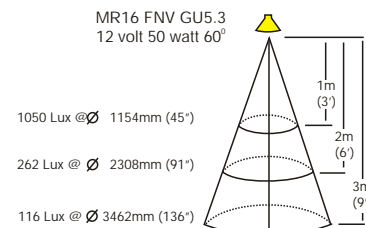
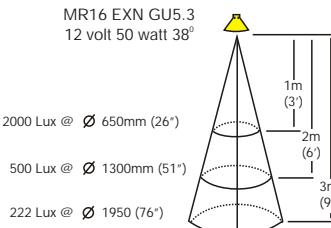
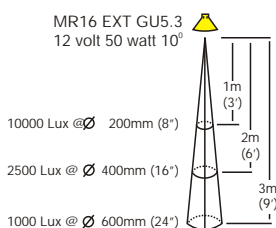
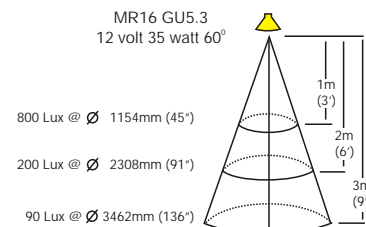
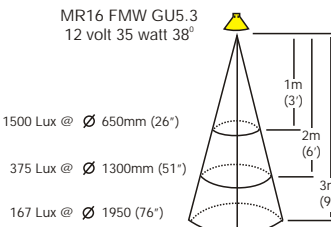
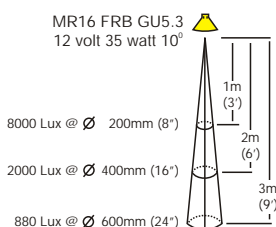
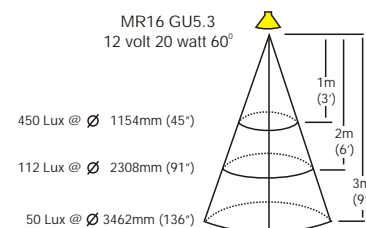
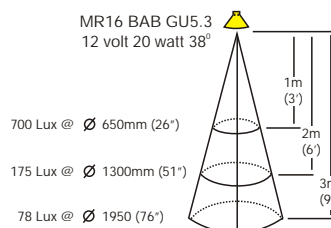
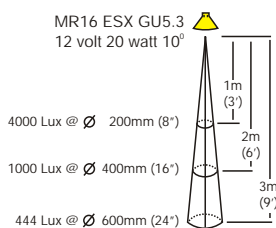

FACTORY: Ph: 64-9-528 9471 Fax: 64-9-528 9361.  
USA: Ph. 310 560 7310 Fax. 1 877 692 4589.  
hunza@hunza.co.nz www.hunza.co.nz  
Specifications may change without notice.

130 Felton Matthew Ave, Glen Innes, Auckland, New Zealand.  
3237 Long Island St, W. Sacramento, California 95691, USA.  
Manufactured in New Zealand.

© 2003 Hunza Holdings Ltd