

# Path Lite

Cat. No. PL  
Cat. No. PLfl

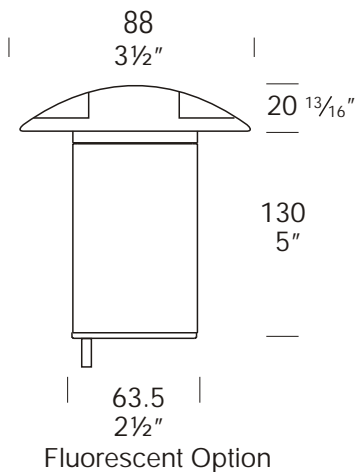
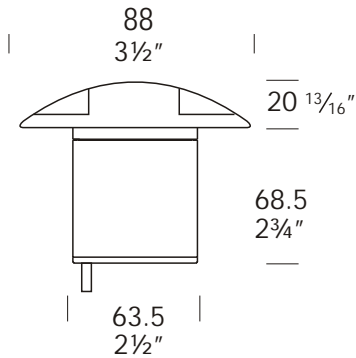

The Path Lite is ideal for lighting flat areas, decks, paved courtyards, edge lighting paths. This luminaire has a low profile 20mm (3/4") and directs light horizontally via a stainless steel reflector cone through a frosted glass lens to reduce glare. Available with 1, 2, 3 or 4 facets for light to be projected through. The Path Light 2 facet may be used as a Step Lite in a wall or fence, etc. to shine light up and down.

A 240 volt 5 watt fluorescent option is available which offers excellent light output, low energy usage low heat generation, this changes the luminaire to an IP66 rating.

## Ordering Information

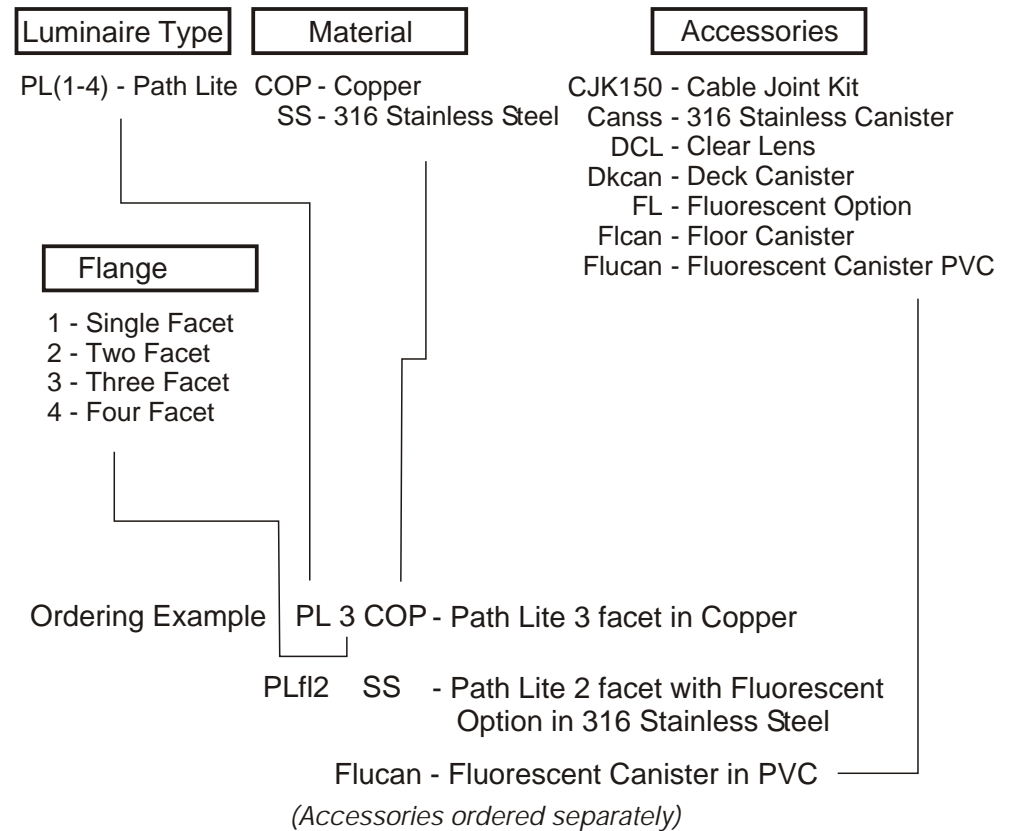

Patent Pending



FACTORY: Ph: 64-9-528 9471 Fax: 64-9-528 9361.  
USA: Ph. 310 560 7310 Fax. 1 877 692 4589.  
hunza@hunza.co.nz www.hunza.co.nz  
Specifications may change without notice.

130 Felton Matthew Ave, Glen Innes, Auckland, New Zealand.  
3237 Long Island St, W. Sacramento, California 95691, USA.  
Manufactured in New Zealand.

© 2003 Hunza Holdings Ltd

## Luminaire Construction

CNC machined from one of the following metals:

Copper: 63.5mm (2½") x 10mm (13/32"). End cap - solid copper 63.5mm (2½") rod.  
Flange 90mm (3½") solid copper rod.

316 Stainless steel: 9mm (11/32"). End cap - solid 316 stainless steel 63.5mm (2½") rod.  
Flange 90mm (3½") solid 316 stainless steel rod.

## Mounting

Floor Lite canister (see accessories) can be used for casting into concrete or a Deck Lite canister for mounting into a wooden deck. Two screws holes in the flange can be specified if canisters are not required.

## Features

**Lens:**  
3mm (1/8") thick frosted tempered shatter resistant glass.  
Life Time Warranty.

**Gaskets:**  
Silicone, iron impregnated 220°C (428°F).

**Lamp Holders:**  
GU5.3 - 350°C (662°F) ceramic multi contact lamp holder with 250°C (480°F) teflon cables.

**Fluorescent**  
E27 PET 210° (410°F) base mount.

## Accessories:

Cable Joint Kit (Cat. CJK 50)  
Not approved for USA /Canada.

Clear Lens (Cat. DCL).

Deck Light Canister (Cat. DKcan).

Floor Canister (Cat. Flcan).

Fluorescent Canister PVC (Cat. Flucan) IP66.

Fluorescent Option 5 watt 240 volt (Cat. FL).

316 Stainless Canister for use in lime stone etc. (Cat. Canss).

## Standards

IP66 / IP68



UL1838

## Luminaire Weight

**12 volt**  
Cop 1.430kg (3lb 2oz)  
SS 1.105kg (2lb 6oz)

**Fluorescent IP66**  
Cop 2.365kg (5lb 3oz)  
SS 1.740kg (3lb 13oz)

## Power Supply

HUNZA® Inground or Wall Mount Transformer: not included.

## USA and Canada:

HUNZA® Wall Mount Transformer: not included.

## Luminaire: supplied with

### Halogen

MR16 GU5.3 20 watt lamp max.

### Fluorescent I

E27 - 240 volt 5 watt self ballasted lamp.

## USA and Canada:

MR16 GU5.3 20 watt lamp max.

Path Lite 4 facet MR16 ESX 20 watt lamp - Lens height 5mm (¼")

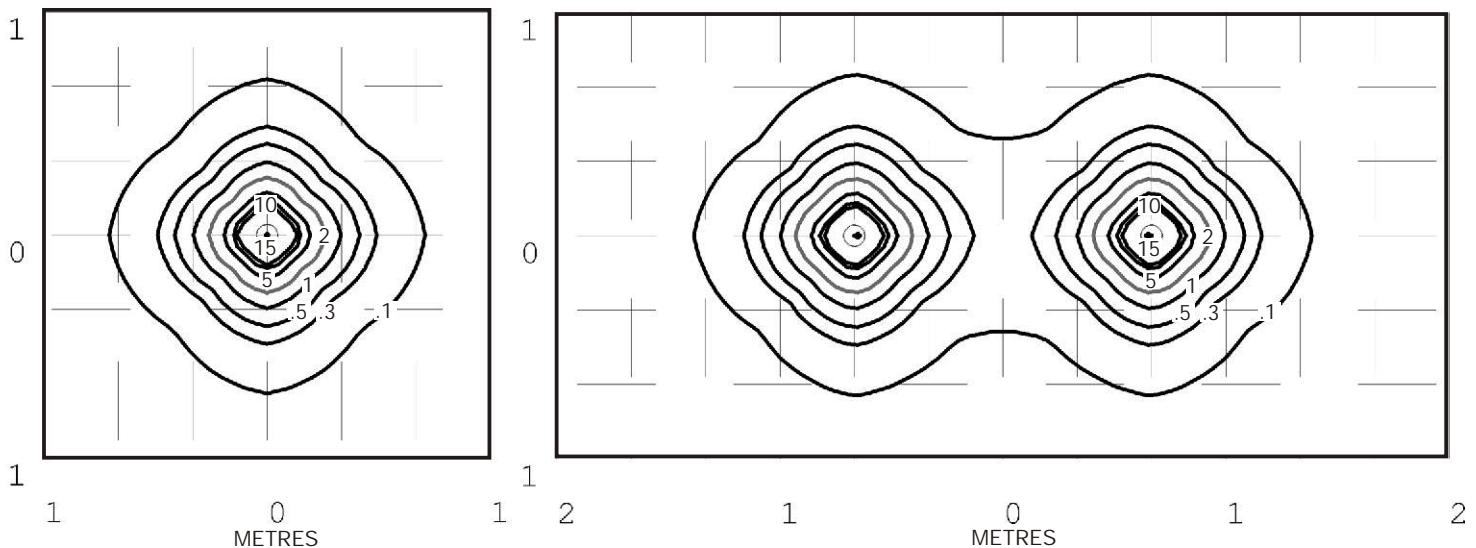

Isolux Lumens Plot - Footcandles = Isolux figures divided by 10.76



FACTORY: Ph: 64-9-528 9471 Fax: 64-9-528 9361.  
USA: Ph. 310 560 7310 Fax. 1 877 692 4589.  
hunza@hunza.co.nz www.hunza.co.nz  
Specifications may change without notice.

130 Felton Matthew Ave, Glen Innes, Auckland, New Zealand.  
3237 Long Island St, W. Sacramento, California 95691, USA.  
Manufactured in New Zealand.

© 2003 Hunza Holdings Ltd