

Pagoda Lite

Cat. No. PGL

Cat. No. PGL/Fl

Cat. No. PGL/R

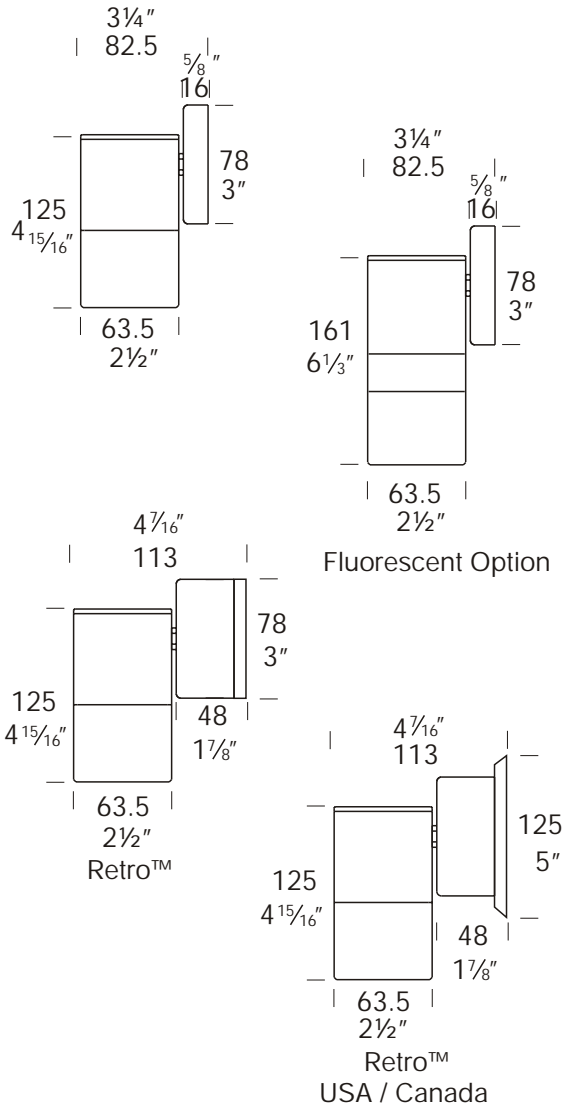

The Pagoda Lite produces a general lighting effect. This luminaire is not for directional lighting. The lens is manufactured from high quality UV stable acrylic with stainless anti-glare mesh.

The Retro™ is a 110/240 ac mains option suited to an installation where mounting a transformer is a problem, e.g. a brick wall where there is only the cable protruding out of the wall and it is not an option to recess the transformer or when replacing an existing light fitting. The base size increases in size to accommodate the encapsulated IP66 dimmable transformer.

A 240 volt fluorescent option is available which offers excellent light output, low energy usage and very low heat generation.

Ordering Information

Luminaire Type

PGL - Pagoda Lite

Material/Finish

BK - Black
 BZ - Bronze
 GN - Green
 MS - Metallic Silver
 WH - White

COP - Copper
 SS - 316 Stainless Steel

Accessories

CJK150 - Cable Joint Kit
 FL - Fluorescent Option
 /R - Retro Transformer 110/240 Volt
 WBAP - Wall Box Adaptor Plate

Ordering Example

PGL BZ - Pagoda Lite in Bronze

WBAP BZ - Wall Box Adaptor Plate in Bronze
 (Accessories ordered separately)



Patent Pending



FACTORY: Ph: 64-9-528 9471 Fax: 64-9-528 9361.
 USA: Ph. 310 560 7310 Fax. 1 877 692 4589.
 hunza@hunza.co.nz www.hunza.co.nz
 Specifications may change without notice.

130 Felton Matthew Ave, Glen Innes, Auckland, New Zealand.
 3237 Long Island St, W. Sacramento, California 95691, USA.
 Manufactured in New Zealand.

© 2003 Hunza Holdings Ltd

Luminaire Construction

CNC machined from one of the following metals:

Body: High corrosion resistant low copper 63.5mm (2½") x 10mm (25/64") aluminium.

Base & Mounting Plate: Cast from virgin high corrosion resistant CC401 low copper aluminium alloy chromate substrate and high UV resistant polyester powder coat - Black, Bronze, Green, Metallic Silver, White.

Copper: Body 63.5mm (2½") x 10mm (25/64").

Base: Hand spun Copper 2mm (5/64"). Mounting Plate: Forged brass (Retro™)

316 Stainless Steel: Body 45.4mm (1¾") rod.

Base: Investment cast and CNC machined.

Mounting Plate: Investment cast and CNC machined. (Retro™)

Mounting

12 volt: the luminaire is mounted to the wall using two 316 stainless screws through a shallow base 16mm (5/8") in depth. A Wall Box Adaptor Plate (Cat. WBAP) is available as an accessory to fit 3.0 and 4.0 junction boxes for USA /Canada.

Retro™ luminaire (110/240 volt): a mounting plate is fixed to the wall using two screws and the luminaire is fitted to the mounting plate.

Features

Lens:

UV stable clear acrylic with anti-glare mesh.

Gaskets:

Silicone, iron impregnated 220°C (428°F)

Lamp Holders:

GU4 - 350°C (662°F) ceramic multi contact lamp holder with 250°C (480°F) teflon cables.

Fluorescent:

E27 PET 210° (410°) base mount.

Accessories:

CJK150 Cable Joint Kit (Cat.CJK150). Not approved for USA /Canada.

Fluorescent Option 5 watt 240 volt (Cat. FL).

Retro™ Transformer 110/240 Volt (Cat. /R).

Wall Box Adaptor Plate USA/ Canada (Cat. WBAP 12 volt luminaire).

Standards

IP66 AS/NZS61046  UL1838

Luminaire Weight

12 volt

Alum .510kg (1lb 1oz).
Cop 1.220kg (2lb 11oz)
SS 1.120kg (2lb 7oz)

Retro™

Aum .840kg (1lb 13oz)
Cop 1.500kg (3lb 4oz)
SS 1.460kg (3lb 3oz)

Power Supply

12 volt

HUNZA® Inground or HUNZA® Wall Mount Transformer: not included.

USA/ Canada

HUNZA® Wall Mount Transformer: not included

RETRO™

HUNZA® 110/240 volt ac silicone encapsulated electronic transformer built into the Retro base. Dimmable with a suitable leading edge dimmer.

Luminaire: supplied with

G4 Bi-Pin 5, 10, 20 watt lamp max.

Fluorescent

E27 - 240 volt 5 watt self ballasted lamp.

USA and Canada:

G4 Bi-Pin 5, 10, 20 watt lamp max.

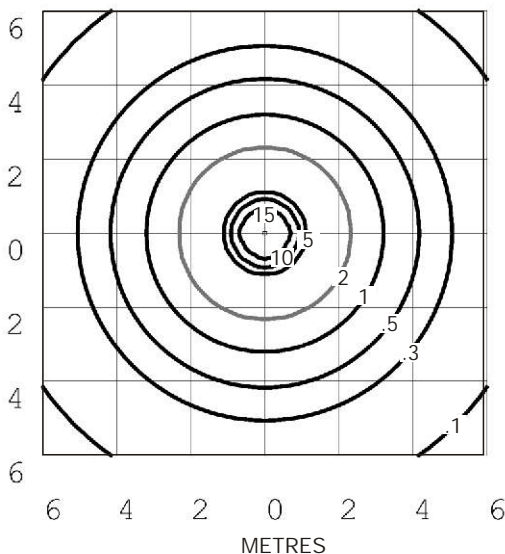

Pagoda Lite GU4 20 watt Bi-Pin lamp - Lens height 1600mm (63")

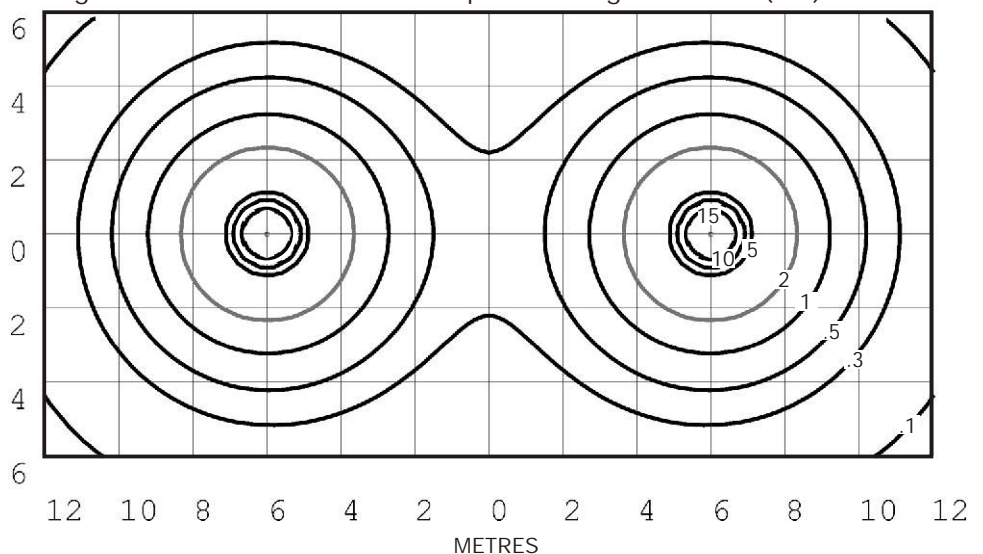

Isolux Lumens Plot - Footcandles = Isolux figures divided by 10.76



FACTORY: Ph: 64-9-528 9471 Fax: 64-9-528 9361.

USA: Ph. 310 560 7310 Fax. 1 877 692 4589.

hunza@hunza.co.nz www.hunza.co.nz

Specifications may change without notice.

130 Felton Matthew Ave, Glen Innes, Auckland, New Zealand.

3237 Long Island St, W. Sacramento, California 95691, USA.

Manufactured in New Zealand.

© 2003 Hunza Holdings Ltd