

Floor Lite

Cat. No. FL

Cat. No. FLfl

Cat. No. FLLED

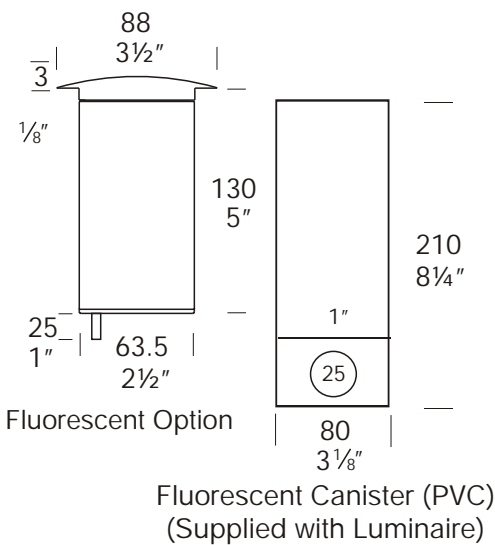
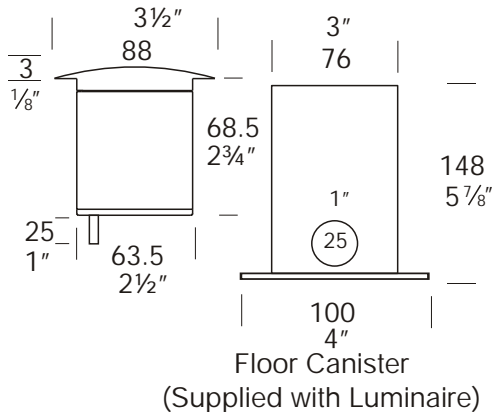

The Floor Lite has an extremely low profile (3mm) and can be walked upon without damaging the luminaire. There are five flange designs: Clover, Grill, Louvre (45 degree angle), Spot, Cross and is supplied with a mounting canister.

A 240 volt 5 watt fluorescent option is available which offers excellent light output, low energy usage and very low heat generation, this changes the luminaire to an IP66 rating.

Ordering Information

Luminaire Type	Material	Accessories
FL - Floor Lite	316 Stainless Steel	CJK150 - Cable Joint Kit Canss - 316 Stainless Steel Canister DFL - Frost Lens Dkcan - Deck Canister FLcan - Floor Lite Canister FL - Fluorescent Option Flucan - Fluorescent Canister HCL - Hex Cell Adaptor (Note: Supplied as standard for USA/Canada) LED - LED Array /TLED - Electronic LED Transformer (Installed inside luminaire)
Flange		
CL - Clover (A)		
CR - Cross (E)		
GR - Grill (B)		
LU - Louvre (C)		
SP - Spot (D)		

Ordering Example: FL LU - Floor Lite Louvre (C)
316 Stainless Steel

FL SPfl - Floor Lite in 316 Stainless Steel
Spot (D) with fluorescent option

LED/BU - LED array in Blue
(Accessories ordered separately)

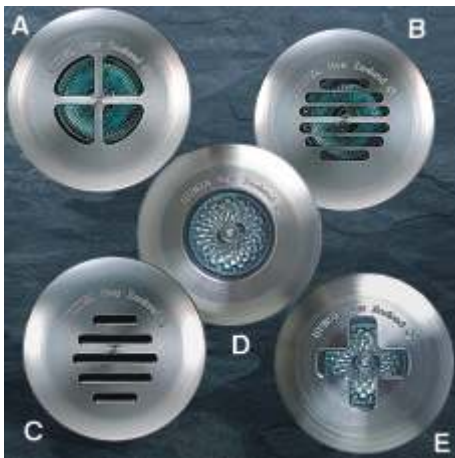

Patent Pending



FACTORY: Ph: 64-9-528 9471 Fax: 64-9-528 9361.
USA: Ph. 310 560 7310 Fax. 1 877 692 4589.
hunza@hunza.co.nz www.hunza.co.nz
Specifications may change without notice.

130 Felton Matthew Ave, Glen Innes, Auckland, New Zealand.
3237 Long Island St, W. Sacramento, California 95691, USA.
Manufactured in New Zealand.

© 2003 Hunza Holdings Ltd

Luminaire Construction

CNC machined from:

Body:

316 Stainless Steel 63.5mm (2½") x 9mm (11/32") . End cap - solid 316 stainless steel 63.5mm (2½") rod.

Flange:

316 Stainless Steel 90mm (3½").

Mounting

The luminaire is pushed into the canister and is held by two silicone "O" rings : Canss, FLcan, Flucan: Cast into concrete, brick, concrete block, etc.

Dkcan: mounted into wooden decks, wooden frames, etc.

Features

Lens:

3mm (1/8") clear tempered shatter resistant glass.

Life Time Warranty.

Gasket:

Silicone, iron impregnated 220°C (428°F).

Lamp Holders:

GU5.3 - 350°C (662°F) ceramic multi contact lamp holder with 250°C (480°F) teflon cables.

Fluorescent

E27 PET 210° (410°F) base mount.

Accessories:

Cable Joint Kit (Cat. CJK 50)
Not approved for USA /Canada.

Deck Canister (Cat. Dkcan).

Frosted Lens (Cat. DFL).

Floor Canister (Cat. Flcan).

Fluorescent Canister PVC (Cat. Flucan).

Fluorescent Option 5 watt 240 volt (Cat. FL) IP66.

Hex Cell Louver Adaptor (Cat. HCL)
(Note: Supplied as standard for USA/Canada).

316 Stainless Canister for use in lime stone etc. (Cat. Canss).

LED Array (Cat. LED) Red, Green, Blue, Yellow, White.

LED Transformer 100 - 240/24 volt 6va. for inside luminaire (Cat./TLED).

Standards

IP66 / IP68



UL1838

Luminaire Weight

SS .995kg (2lb 3oz)

Fluorescent IP66

SS 1.630kg (3lb 10oz)

Power Supply

HUNZA® Inground or Wall Mount
Transformer: not included.

HUNZA® H20/24LED: not included.

HUNZA® IG20/24LED: not included.

Electronic transformer 100 - 240 volt 50/60Hz. 24 volt d.c.6va: not included.

USA and Canada:

HUNZA® Wall Mount Transformer:
not included.

Electronic transformer 100 - 240 volt 50/60Hz. 24 volt d.c. 6va: not included.

Luminaire: supplied with

MR16 GU5.3 - 20 watt lamp max.

LED

LED Array 24 volt d.c. 1.2 watt.

Fluorescent

E27 - 240 volt 5 watt self ballasted lamp.

USA and Canada:

MR16 GU5.3 20 watt lamp max.

LED

LED Array 24 volt d.c. 1.2 watt.

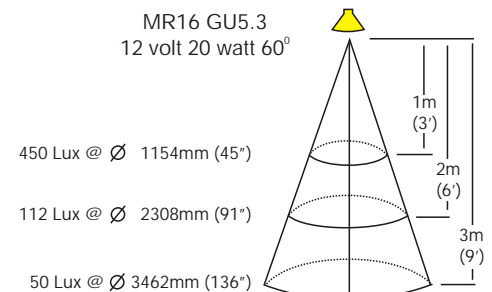
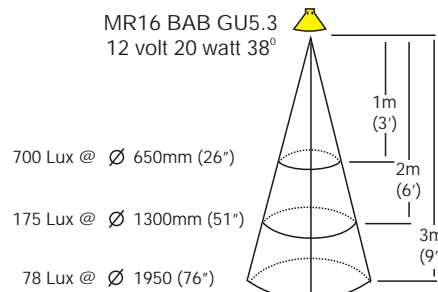
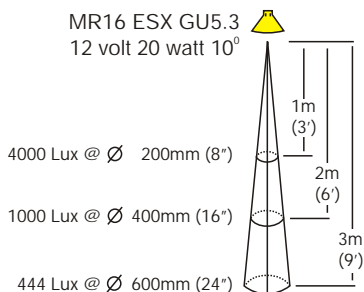

These diagrams refer to the Spot Lite Flange (D) only.



FACTORY: Ph: 64-9-528 9471 Fax: 64-9-528 9361.

USA: Ph. 310 560 7310 Fax. 1 877 692 4589.

hunza@hunza.co.nz www.hunza.co.nz

Specifications may change without notice.

130 Felton Matthew Ave, Glen Innes, Auckland, New Zealand.

3237 Long Island St, W. Sacramento, California 95691, USA.

Manufactured in New Zealand.

© 2003 Hunza Holdings Ltd