

# Euro Step Lite

Cat. No. ESL



The Euro Step is designed for use with an MR11 lamp. It has a 69mm flange for flush mounting into masonry, stone or wood. For illumination of steps and ground level horizontal lighting, for example, across driveways or exterior paved areas. There are no mounting screws in the flange to spoil the aesthetics of this luminaire.

## Ordering Information

### Luminaire Type

ESL - Euro Step Lite

### Material

COP - Copper  
SS - 316 Stainless Steel

### Accessories

CJK150 - Cable Joint Kit  
Elcan - Euro Lite Canister  
EFL - Frost Lens  
LED - LED Array

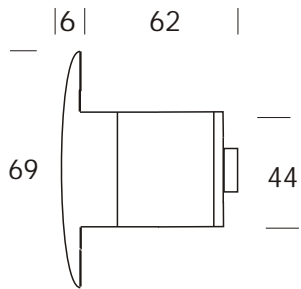

Ordering Example: ESL - Cabin Lite in 316 Stainless Steel.

LED/WH - LED Array in White

*(Accessories ordered separately)*



FACTORY: Ph: 64-9-528 9471 Fax: 64-9-528 9361.  
USA: Ph. 310 560 7310 Fax. 1 877 692 4589.  
hunza@hunza.co.nz www.hunza.co.nz  
Specifications may change without notice.

130 Felton Matthew Ave, Glen Innes, Auckland, New Zealand.  
3237 Long Island St, W. Sacramento, California 95691, USA.  
Manufactured in New Zealand.

© 2003 Hunza Holdings Ltd

## Luminaire Construction

CNC machined from:

Body:

45mm Copper (1¾") rod.

Flange:

70mm (3½") solid copper rod.

Body:

45mm (1¾") 316 Stainless steel rod.

Flange:

70mm (3½") solid 316 stainless steel rod.

## Mounting

The Euro Step Lite is fixed in place using a mounting canister. There are no mounting screws in the flange to spoil aesthetics of the luminaire.

## Features

### Lens:

3mm (1/8") thick clear tempered shatter resistant glass.  
Life Time Warranty.

### Gaskets:

Silicone, iron impregnated 220°C (428°F).

### Lamp Holder:

GU4 - 350°C (662°F) ceramic multi contact lamp holder with 250°C (480°F) teflon cables.

### Accessories:

Cable Joint Kit (Cat. CJK 50)  
Not approved for USA /Canada.

Euro lite Canister (Cat. Elcan)

Frosted Lens (Cat. EFL).

LED Array (Cat. LED) Red, Green, Blue, Yellow and White.

## Standards

### IP66

USA and Canada:

Not approved.

### Luminaire Weight

Cop .480kg (1lb)

SS .415kg (14oz)

### Power Supply

HUNZA® H20/24LED.

HUNZA® IG20/24LED.

### Lamp Type

#### Halogen

MR11 GU4 20 watt lamp max.

#### LED

LED Array 24 volt dc 1.2 watt

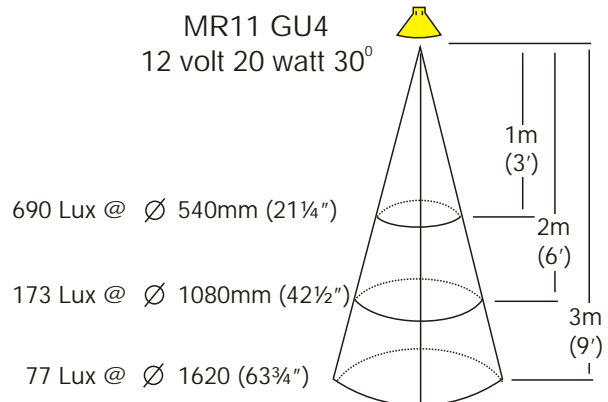
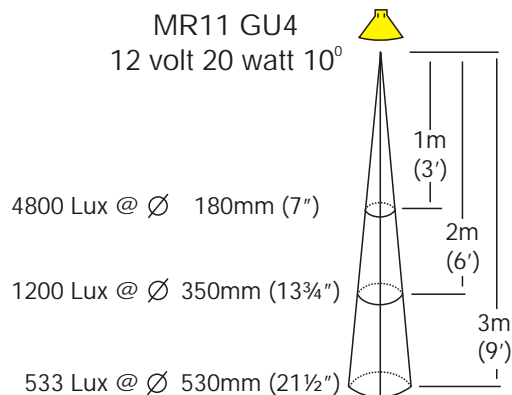

FACTORY: Ph: 64-9-528 9471 Fax: 64-9-528 9361.

USA: Ph. 310 560 7310 Fax. 1 877 692 4589.

hunza@hunza.co.nz www.hunza.co.nz

Specifications may change without notice.

130 Felton Matthew Ave, Glen Innes, Auckland, New Zealand.

3237 Long Island St, W. Sacramento, California 95691, USA.

Manufactured in New Zealand.

© 2003 Hunza Holdings Ltd