

Cabin Lite

Cat. No. CL



The Cabin Lite has an anodised canister for corrosion protection and is open at the top to allow heat to escape and is designed for interior use on a boat or ship. There are no mounting screws in the flange to spoil the aesthetics of this luminaire, it is available only in 316 stainless steel.

Ordering Information

Luminaire Type

CL Cabin Lite

Material

SS - 316 Stainless Steel

Accessories

CJK150 - Cable Joint Kit
EFL - Frost Lens
LED - LED Array
/TLED - Electronic LED Transformer

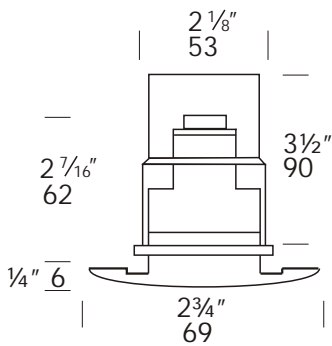

Ordering Example: CL - Cabin Lite in 316 Stainless Steel.

LED/WH - LED Array in White
(Accessories ordered separately)



FACTORY: Ph: 64-9-528 9471 Fax: 64-9-528 9361.
USA: Ph. 310 560 7310 Fax. 1 877 692 4589.
hunza@hunza.co.nz www.hunza.co.nz
Specifications may change without notice.

130 Felton Matthew Ave, Glen Innes, Auckland, New Zealand.
3237 Long Island St, W. Sacramento, California 95691, USA.
Manufactured in New Zealand.

© 2003 Hunza Holdings Ltd

Luminaire Construction

CNC machined from:

Body:

316 Stainless steel: 45mm (1¾") rod.

Flange:

70mm (3½") solid 316 stainless steel rod.

Canister:

Open ended anodised aluminium canister for heat dispersion.

Mounting

The Cabin Lite is fixed in place using the locking ring on the canister. It will mount into material up to 15mm thick. There are no mounting screws in the flange to spoil the luminaire aesthetics.

Features

Lens:

3mm (1/8") thick clear tempered shatter resistant glass.
Life Time Warranty.

Gaskets:

Silicone, iron impregnated 220°C (428°F).

Lamp Holder:

GU4 - 350°C (662°F) ceramic multi contact lamp holder with 250°C (480°F) teflon cables.

Accessories:

Cable Joint Kit (Cat. CJK 50)
Not approved for USA /Canada.

Frosted Lens (Cat. EFL).

LED Array (Cat. LED) Red, Green, Blue, Yellow and White.

Electronic LED Transformer 100 - 240volt 24 v d.c. 6va. (Cat /TLED).

Standards

IP66

USA and Canada:

Not approved.

Luminaire Weight

SS .415kg (14oz)

Power Supply

HUNZA® H20/24LED.

HUNZA® IG20/24LED.

100 - 240 volt 50/60Hz. 24 volt d.c.
6va electronic transformer: not included.

Luminaire: supplied with

Halogen

GU4 Bi-Pin 20watt lamp max.

LED

LED Array 24 volt dc 1.2 watt



FACTORY: Ph: 64-9-528 9471 Fax: 64-9-528 9361.

USA: Ph. 310 560 7310 Fax. 1 877 692 4589.

hunza@hunza.co.nz www.hunza.co.nz

Specifications may change without notice.

130 Felton Matthew Ave, Glen Innes, Auckland, New Zealand.

3237 Long Island St, W. Sacramento, California 95691, USA.

Manufactured in New Zealand.

© 2003 Hunza Holdings Ltd